



CONTACTS FOR MAINTANANCE AND MANUFACTURING

Adress : Karadenizliler Mah. Işıklı Sok. No:3
Başiskele / KOCAELİ

Telephone : +0090 262 335 24 00

Fax : +0090 262 335 24 15

Mail : info@kosmak.com

Website : www.kosmak.com

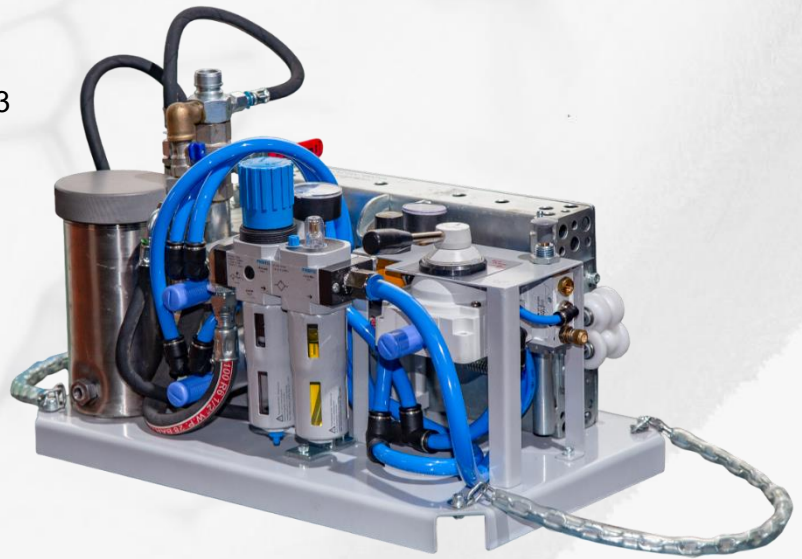

FOK Machine

FOK MACHINE

Fiber Optic Cable Blowing Machine



KOSMAK MACHINE HISTORY

Our company has been in the machinery and machinery spare parts manufacturing sector since 1994. Since 1999, almost all of the fiber cable blowing works in Turkey have been done using fiber optic cable blowing machines produced by KOSMAK MACHINE.

It continues its R&D activities on fiber blowing machines and revisions are made according to customer requests.

Fiber optic cable blowing machines produced by Kösmak Makina are used in many countries of the world, especially in Italy, the Netherlands, Uruguay, Holland, Germany, England, African Countries, Canada, USA, Syria, Iraq, Romain, Bulgaria, Kazakhstan, Libya and Suudi Arabia.

OUR UNDERSTANDING OF QUALITY;

Based on the principle of customer satisfaction first, our focus is to fully perceive customer demands and expectations and provide complete products and services accordingly,

To achieve this goal;

- Continuously improving product quality, reducing costs while increasing product qualities,
- To fully meet technological infrastructure and personnel information needs,
- Aiming for continuous improvement as a whole with the participation of employees.

OUR MISSION

To be the first choice of our customers with our products, solutions, after-sales services, reliability and high business ethics.

OUR VISION

To be a leader in its country and a preferred company in the world with its organization that that makes makes a name for itself in the technological developments in the sector in which it produces products and services, adds value to the lives of its customers and the society in which it operates, is admired for its performance in the solution partnerships it establishes with its customers, and adopts sustainable development as its working culture.

Fiber Optic Cable Blowing Machine (FOK)

The FOK Cable Blowing Machine offers users a complete solution with its flexible and compact design. It allows for easy and fast installation of fiber optic cables and micro ducts. Cable diameters can range from Ø6 to Ø22mm, while duct outer diameters (OD) can vary between Ø20mm and Ø50mm. The FOK Machine is designed to blow fiber optic cables into pre-installed ducts. This multifunctional machine can easily handle cable and microduct installation using compressed air and accommodates a wide range of cable diameters.

The FOK Machine provides high productivity and significantly increases your workforce capacity. Its carefully designed pneumatic pressure pallet system ensures excellent cable blowing performance and reduces the risk of damage. The pneumatic pressure system minimizes fluctuations in cable outer diameter. Additionally, the machine is engineered and manufactured with high technology to meet and exceed customer expectations.

The FOK Machine is a cable blowing machine designed to install fiber optic cables into pre-installed telecommunication ducts and microducts using compressed air. It features four pallet options: Ø6–Ø9 mm, Ø6–Ø9 mm, Ø9–Ø13 mm, Ø14–Ø18 mm, and Ø19–Ø22 mm, allowing cables from Ø6 mm to Ø22 mm to be blown at speeds of up to 100 m/min. Duct diameters can range from Ø20 mm to Ø50 mm. The special pallet design ensures cable installation even in muddy field conditions without reducing blowing power. Cable installation speed and direction can be adjusted using the control valve.

The efficiently designed exit box directs compressed air into ducts with high efficiency. The quick air connection simplifies operations with an easy plug-in method. The shock lubrication system allows lubricant to be transferred into pre-installed ducts, reducing friction between the duct and the cable. Two air motors provide continuous, high-efficiency cable blowing power. Air valves allow you to control the airflow into the ducts. The Festo lubrication system removes moisture from the compressed air coming from the compressor and provides continuous lubrication to the air motors.

Thanks to the quick-connect fitting, you can easily connect the compressed air from the compressor to the machine.

You can install your cable in muddy fields with our special designed palettes. Cable blowing power will not decrease.

Pneumatic press system don't let cable to skid and damage.



This festo lubricant system takes off moisture of pressured air which comes form compressor and supplies continous lubricate for air motors.

Special designed exit box supplies productive guiding for pressure air into pre-installed duct.

You can transfer oil (Lubricom-f) into pre-installed duct with this shock lubrication system to reduce friction between duct and cable.

FOK CONTENT

INCLUDING WITH MACHINE

- | | | |
|--------------------------------|--------------------------|---|
| ❖ 1 set (2pct) of Pallet | ❖ 1 pcs Operator Guide | ❖ 1 pcs Protected Wooden Case with holder |
| ❖ 1 pcs Duct Lubricant System | ❖ 1 pcs Cable Inserts | ❖ 1 pcs Quick Insert Air Jack |
| ❖ 2 pcs Air Motor | ❖ 1 set Duct Inserts | ❖ 1 set Tool Kit |
| ❖ 1 pcs Air Lubrication System | ❖ 1 set Blue Nutring | ❖ 1 pcs Box for plastic tools |
| ❖ 1 set Cable Aligning Parts | ❖ 2m Black Rubber O-Ring | |

NOT INCLUDING WITH MACHINE

- ❖ Air Cooler
- ❖ Lubricant Oil
- ❖ Air Compressor

TECHNICAL DATA

- | | |
|---|------------------------------------|
| ❖ Standart version | 2 pcs of pneumatic motor drive |
| ❖ Type | FOK |
| ❖ Cable dia. [mm] | Ø6-Ø22 |
| ❖ Pallet Options [mm] | Ø6-Ø9 / Ø9-Ø13 / Ø14-Ø18 / Ø19-Ø22 |
| ❖ Duct OD [mm] | Ø20-Ø32-Ø40-Ø50 |
| ❖ Drive unit | Pneumatic |
| ❖ Max. air consumption of 2 pcs of motor [m ³ /min] | 3 m ³ / min (at 6 bar) |
| ❖ Torque Nm - Max. Power | 8.5 Nm x 2 Pieces |
| ❖ Max. distance to blow at once
(Cable Dia. 12 mm - Duct Dia.40mm) (m) | 3000 |
| ❖ Max. speed [m/min] | 100 |
| ❖ Max. air pressure [bar] | 16 |
| ❖ Max. water pressure [bar] | 23 |
| ❖ Dimension of apparatus with case lwx h [mm] | 380 x 610 x 440 |
| ❖ Weight of machine [kg] | 40 |
| ❖ Total weight [kg] | 49 |

F.O.K. MACHINE PARTS

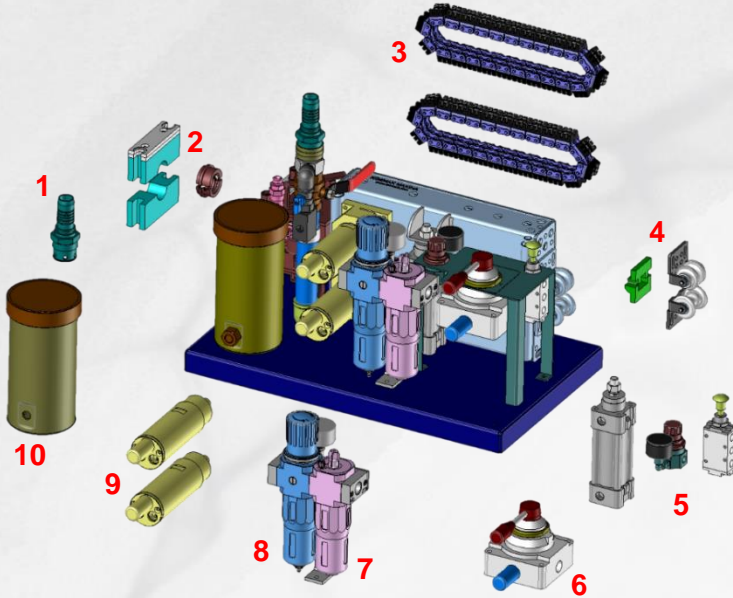

- 1) Quick Pipe Connection
- 2) Easy Duct Connection
- 3) Rubber coated chain for pushing cable without skidding.
- 4) Cable aligning parts to blow cable ahead.
- 5) Pressure regulator with piston group to regulate pushing force on cable and to make up&down movement automatically.
- 6) Direction control valve for pushing and pulling fiberoptic cable.
- 7) Air lubricating unit to lubricate air motors during cable blowing.
- 8) Pressure regulating unit to regulate air pressure on air motors.
- 9) Two air motors pushing cable together.
- 10) Duct lubrication unit to lubricate duct during cable blowing.

F.O.K. ACCESSORIES

COMPRESSOR CAPACITY RECOMMENDATION

Efficiency	10,5 m ³ /min
Working Pressure	12 Bar

These are minimum compressor requirements. You may use higher capacity of compressor which can increase the effectiveness. You can overcome the handicap of improperly installed ducts.

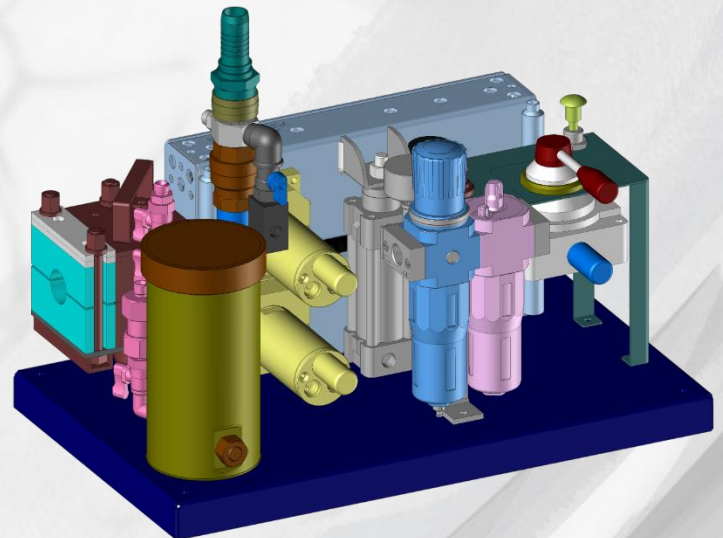

PALLET, CABLE, CABLE ALIGNING AND DUCT OPTIONS

In the F.O.K. Machine; the entry aligning rollers, pallets, exit aligning plastics, nutring seals, duct reducers, and duct couplings are subject to variation depending on the cable and duct diameters.

For your order, the appropriate components must be selected according to the cable and duct diameter you intend to use, by referring to the stock numbers specified in the lists below.

NOTE: In addition to the dimensions indicated in the list, customized sizes can also be manufactured upon request.)



**Pallet Set
(mm)**

P1 : Ø6-Ø9
P2 : Ø9-Ø13
P3 : Ø14-Ø18
P4 : Ø19-Ø22



**Nutring Seals
(mm)**

NS1 : Ø6 NS6 : Ø17
NS2 : Ø7 NS7 : Ø18
NS3 : Ø8 NS8 : Ø19
NS4 : Ø9-Ø14 NS9 : Ø20-Ø21
NS5 : Ø15-Ø16 NS10 : Ø22

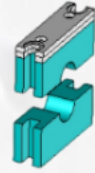

**Duct Couplings
(mm)**

D1 : Ø20
D2 : Ø25
D3 : Ø32
D4 : Ø40
D5 : Ø50



**Alignig Rollers
(mm)**

AR1 : Ø6-Ø14
AR2 : Ø14-Ø22



**Alignig Plastics
(mm)**

AP1 : Ø6-Ø8
AP2 : Ø9-Ø14
AP3 : Ø15-Ø22



**Duct Reducers
(mm)**

DR1 : Ø20
DR2 : Ø25
DR3 : Ø32
DR4 : Ø40

For order placement, please indicate the stock codes of the required products selected from the above lists, in accordance with the example provided below.

Example : P1 + NS2 + NS3 + D3 + AR1 + AP1 +DR3

Note: 1 set of Pallet - 1 Set of Cable Aligning Tool + 1 pcs Duct Connection Tool is included

SELECTING AND LOCATING CABLE SEALS



Figure 1



Figure 2



Figure 3



Figure 4

Firstly measure cable diameter with callipers (figure 1). The selected cable seals inside diameter (figure 2) must be same with cables outside diameter and it must work slippery on cable (figure 3) not to let air leak. Cut cable seals as you see on figure 4.



Figure 5

Note: You must inform us your cable diameter that you will install with your FOK order. Canals of the selected cable seals must locate to install way of cable. If not, we can not use compressed air productive which comes from compressor (figure 5). Touch faces of black o-rings with cable seals must be cutted angular.

SETTING AXIS CABLE DIAMETER

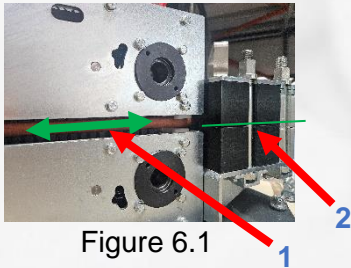

Figure 6.1



Figure 6.2



Figure 6.3

When the cable diameter is changed, the pallet axis and the exit box axis must be aligned to ensure efficient blowing. First, place the cable into the machine as shown in Figure 6.1. Then, align the exit box with the pallet axis so that axis lines No.1 and No.2 (figure 6.1) are at the same level. This adjustment can be made by loosening and tightening the bolts shown in Figure 6.2. Finally, after completing all adjustments, tighten the bolts in Figure 6.3 to secure the upper cover of the exit box. In this way, the cable diameter axis alignment is completed.

Note: If you inform our company about your cable diameter before you buy machine, machine axis will be set by our company. When you will blow different cable diameter, you will have to set axis as we explained up wrench set will be given with machine.

PREPAIRING PULLEYS

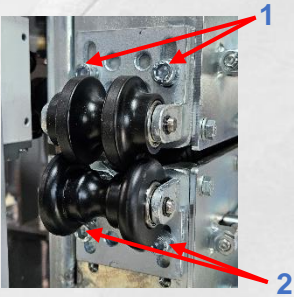

Figure 7

Pulleys on figure enable the cable to go into the machine on axis easily. Pulley's distance is set by bolts. (No.1,2 on figure 7) For cable diameter. Pulley's distance must be closed if not, cable can get out from sides and break.

LOCATING PRE-INSTALLED DUCT AND CABLE

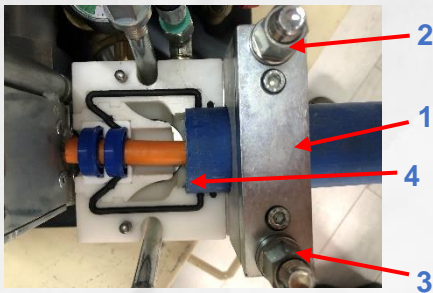

Figure 8

Loosen bolts (No. 2,3 on figure 8) firstly to assemble Duct to machine and then leave the upper part (No:1) Drive duct until the face number 4. Then put the upper part (No:1) on cable and press bolts (No:2,3) to finish duct assemble Locate cable into machine as shown on figure 8.

Note: Selecting cables, setting cable axis, preparing pulleys are done when the cable diameter is changed.

MAKING AIR CONNECTIONS COMING FROM AIR



Figure 9.1



Figure 9.2



Figure 9.3

The fixed body of the quick connection is mounted on the machine as shown in Figure 9.1. The movable part of the quick connection is supplied with the machine as shown in Figure 9.2. To provide the air connection to the machine, first securely connect the 1" air hose to the part shown in Figure 9.2. Then, connect the part with the air hose to the fixed part on the machine as shown in Figure 9.3, again securely. Pull the movable part (Figure 9.2) together with the hose strongly upwards to ensure that it is correctly connected. If the hose and the part do not come off, it means that your machine is now ready for the air connection.

PRESSURE GAUGES, PRESSURE VALUES AND SETTING PRESSURES



Figure 10

1-) Duct Pressure Valve: Duct blown in world standards must have minimum 10.5 bar (You must see this value on gauge shown in figure 10-1) to blow your cable. If not, you can't blow your cable.

2-) Air Motor Pressure: You must see 6.5-7 bar on gauge figure (10-2) when you are blowing. If you work on higher values this will cause your motor pulleys to be damaged and your air motors will break down.

3-) Pallettes Pressure Value: Pneumatic piston supplies pallette pressure. This system prevents the wear on your cable between pallettes. You must set this pressure value with checking weather conditions. Your cable mustn't skid between pallettes in normal conditions this value range must be between 2-4 bars.

SETTING PALLET PRESSURE



Figure 11

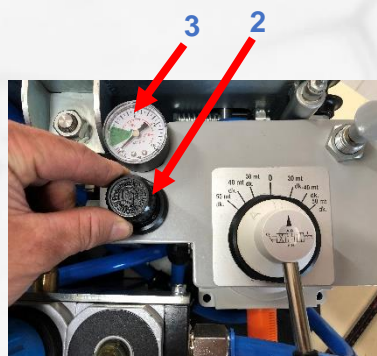

Figure 12

You can set piston pressure (figure 11-1) on pallettes with using regulator (figure 12-2) and you can control pressure on gauge (figure 12-3). Do not increase pressure value too much if you increase it you candamage your cable and air motors.

SETTING AIR MOTOR PRESSURE LUBRICATION STYLE

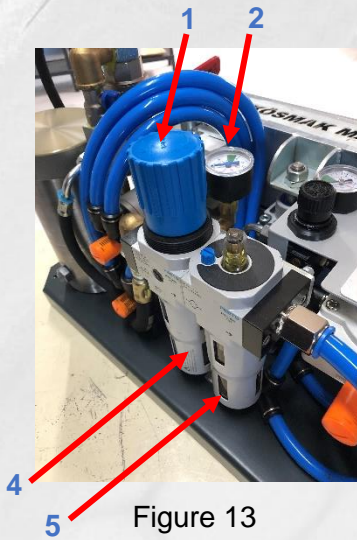

Figure 13



Figure 14

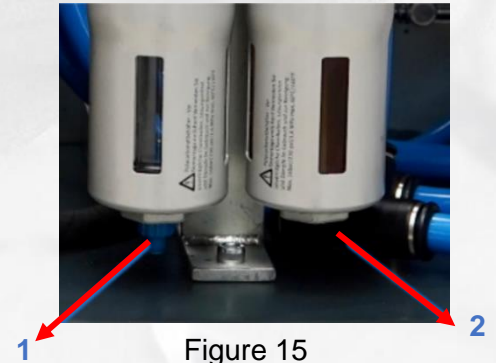

Figure 15

Use the mechanism (figure 13-1) to set pressure of air motors and control on gauge (figure 13-2). Air motors must work between 6.5-7 bar.

The filter (figure 13-4) takes moisture of pressurized air which comes from compressor. Use tap (figure 15-1) to discharge collected moisture. You must do this operation not to let rust the parts of air motors.

Put oil for air motors to reservoir (figure 13-5). And use screw (figure 15-2) to re-fill it. This is necessary to lubricate bearings of air motors.

When the blue stopper opened (figure 14-7) lubrication for air motors will be closed.

Use screwdriver (figure 14-3) to set the amount of oil for air motors. Current amount of oil is one drop in one minute. You can see drop in (figure 14-6)

Note: Our F.O.K is ready to install cable after making the configurations we stated as number 1,2,3,4,5,6. We can start to install our cable by using direction control valve.

USING SHOCK LUBRICANT

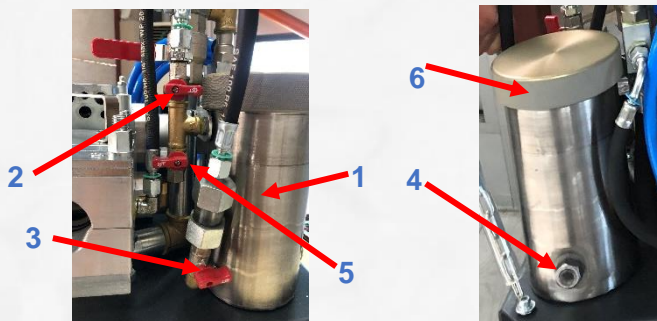

Figure 16

To reduce friction between the cable and the duct, put the special oil (lubricant) into the reservoir (figure 16-1-1). You can see the closed position of the lubrication valves in figure 16-2. To send oil into the duct, first open the valve shown in figure 16-2, then keep the valve in figure 16-3-3 open for 10–15 seconds at 3-minute intervals to pump lubricant oil into the duct.

You can check the oil indicator (figure 16-4) to see if the reservoir needs refilling. For refilling, open the valve shown in figure 16-5 and release the pressurized air. Then close the discharge valve. Next, open the reservoir lid (figure 16-6), add the lubricant oil, and close the lid tightly to prevent any air leakage.

USING DIRECTION CONTROL VALVE



Figure 17

You can regulate fibre optic cable direction and speed (0-80 m/min) by moving direction control valve to right or left.

Note: You must use stop position when you are changing the direction. If you pasa the opposite direction directly and don't stop on stop position this will damage the gears of air motors.

USING PALETTE CONTROL VALVE



3



1

Figure 18



2

Palettes can be opened and closed by using the button shown in figure 18-1. The opening and closing speed of the palettes can be adjusted with the yellow parts in figure 18-2. The palette pressure can be adjusted by using the regulator in figure 18-3.

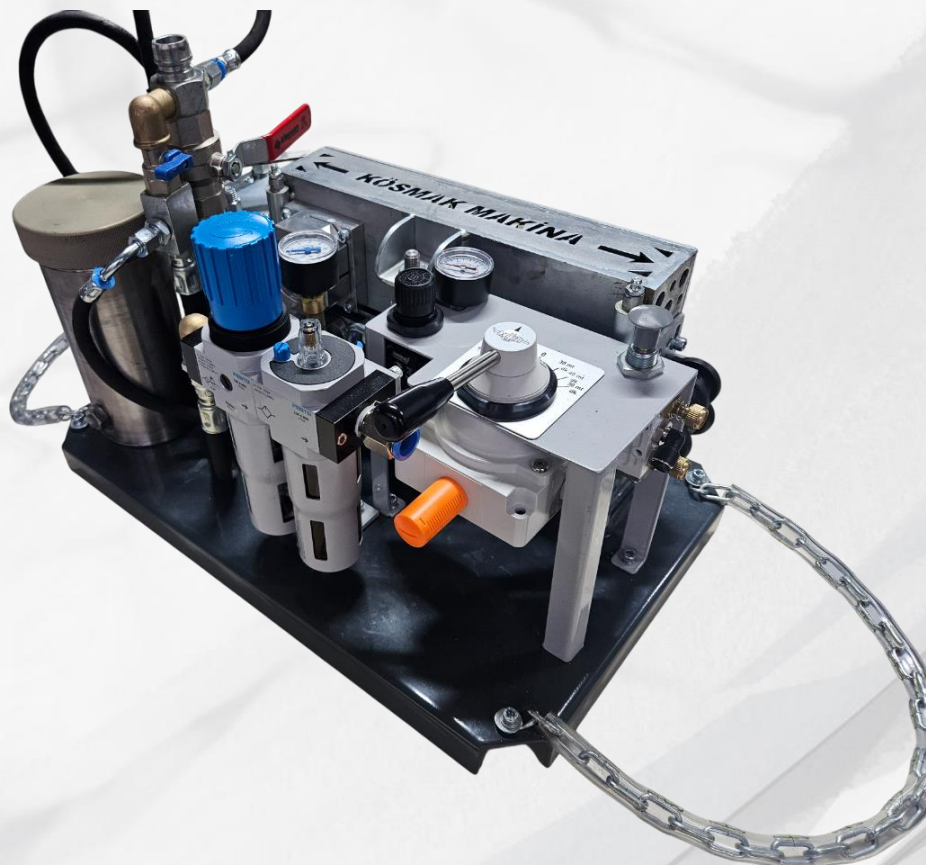

FOK MAINTENANCE INSTRUCTIONS



Figure 19

To maintain air motors, open oil set screw until end (figure 19-1) and run motors 30-35 secs on this position. This operation supplies bearing lubrication for air motors and parts.

1 This operation must be repeated in every evening after the work ends, if not the moisture collected in motors will cause the bearings to rust.

2 The foreign objects entering into reservoir (figure 19-2) causes to the filter be blocked. This changes its colour and its shape. You must change this filter before this case occurs, if not air pressure yield will be less and you will have problems about the machine.



Figure 20

You can see the demontaging of air filter on 20. Firstly open reservoir (figure 20-1) and nut (figure 20-2) then you can take air filter (figure 20-3).

Put our cable seals (figure 21-1) and orings (figure 21-2) to make care of exit box (figure 21). Clean tehir slots with diesel oil and brush. If cable seals and orings are beaten, change them otherwise there will be air leak.

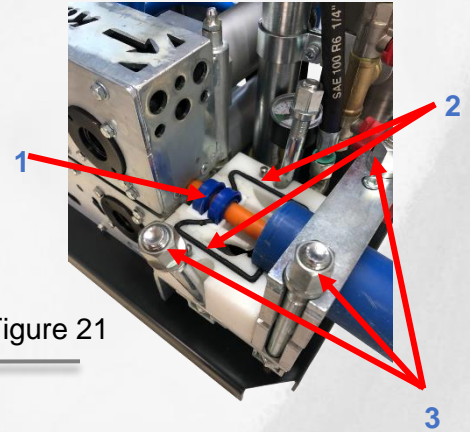

Figure 21

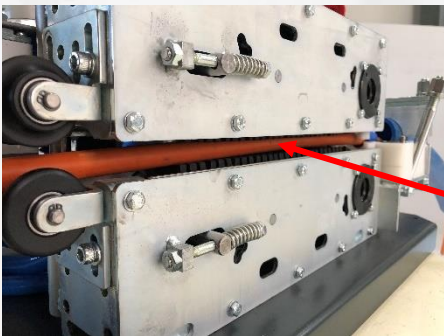

Figure 22

1 Locate your cable in to machine s shown in figure 22. Pallettes mustpress to cable and pallettes mustn't touch each other. If they touch, this means your pallettes are worn away. Pallettes must be changed.



Figure 23



Figure 24

If the blowing area is muddy, mud can go into the pallettes of the machine, you may clean mud with pressured water and using holes as you may see on figure 22 and 23.

SAFETY RULES

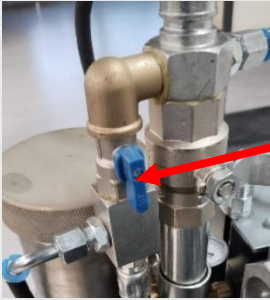

If an unusual situation occurs on the machine, close this valve to cut off the pressurized air coming to the machine, and then quickly shut down the compressor.

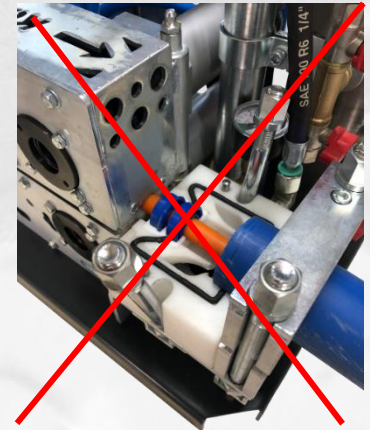

Do not open exit box before evacuating air on exit box.

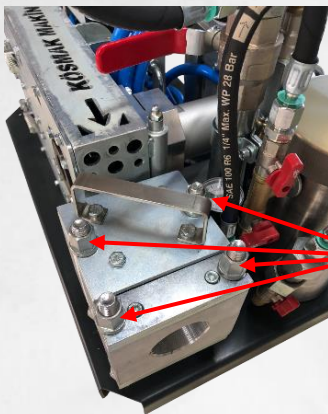

Close nuts correctly before giving air on machine. If nuts and bolts are beaten change them with new ones.

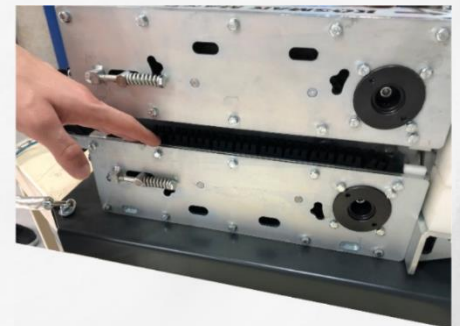

Work machine with only bright places do not touch working parts on machine. Use gloves and ear plugs while working with machine.

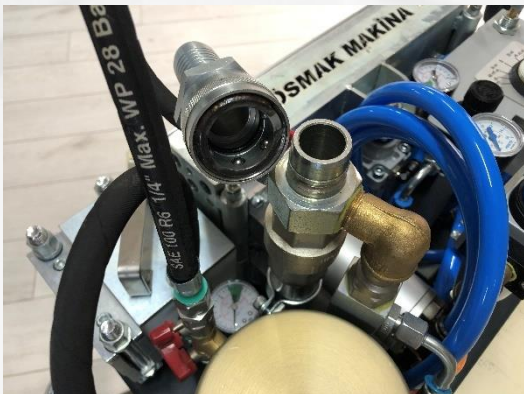

You must check quick connection before giving air to machine. Take up quick connection part as you see in figure to check it. Do not use if it is coming up.



Do not open water tap and oil jar before evacuating air on machine.

TRANSPORTING MACHINE



After taking out in box. Carry cable blowing machine as on figure.



Carry cable blowing machine as on Figure.

IMPOTAND NOTE: TAKE OUT AIR ON MACHINE BEFORE CARRING MACHINE.

CORRECTION OF FAULTS

If your machine can not catch cable and palettes skids on cable, it means that your palettes are damaged and needs to change or palette pressure is low.

If cable exit box squeeze cable it means that cable seals are false chose correct cable seals.

If there is oil or air leaking on exit box palettes side it means that your cable seals are false or montaged false direction

If there is air leaking on exit box, clean surfaces of exit box and change o-rings.

If you machine is working hardly while you are blowing cable, it means that your ducts air pressure can be less, you need to increase your air pressure which is coming from compressor. It must be minimum 12 bar / 10.5 m³/min.

If your cable blowing machine is working but you can not blow cable in ducts is means that your ducts can be plugged. You need to solve the problems in ducts.

If palettes of cable blowing machine is not turning it means that bearings are damaged because of slogging or bearing are rusted because of being in wet situation. You must send machine for maintenance.

If your air motor is not not turning it means that bearing of air motor are damaged you need to send machine to maintenance.

If your air motor is not not turning it means that gears are damaged you need to change gears. You must send machine for maintenance.

If your air pressure on motors are reducing while you are cable blowing it means that your air filter is plugged or damaged you need to change it.

TOOLS GIVEN WITH MACHINE

1) Socket wrench arm set ("T" arm)	1Qty
2) Socket wrech arm set mid part (Long: 25 cm)	1Qty
3) Socket wrench (16mm)	1Qty
4) Open-End wrenchs (8-9 / 10-11)	1Qty
5) Allen wrench (2,5mm / 3mm / 4mm / 5mm / 6mm)	1Qty
6) Screw driver (3x100)	1Qty
7) Stationery knife	1Qty
8) 13" Organizer Plastic Tool Box	1Qty
9) O-ring (Ø95x5)	1Qty
10) Ø3,5 O-Ring 50 cm	1Qty
11) Ø4 O-Ring 50 cm	1Qty
12) Ø8 Air pipe 100 cm	1Qty
13) Ø 14 Air pipe 2 mt	1Qty
14) Ø16 Air pipe 50 cm	1Qty

Note: We set axis line of FOK with the information of cable diameter before sending the machine. We send 10 pieces blue nutrings and 1 piece nutring seal with machine for your cable diameter.

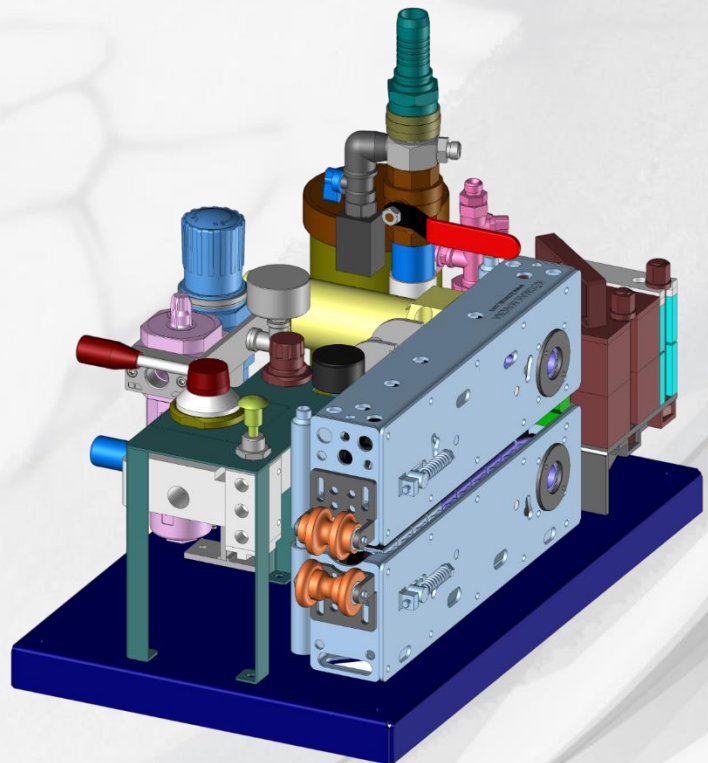

WORKING LAND TERMS

CONDITIONS FOR FIBRE OPTIC CABLE BLOWING MACHINE PRODUCED BY KOSMAK MACHINE BUILDING, INDUSTRY & TRADE CO. THAT YOU HAVE TO CHECK ON WORKING AREA BEFORE YOU START TO WORK.

1) Duct Control

A SPONGE SMALLER THAN THE DIAMETER OF THE DUCT IS PLACED INSIDE THE DUCT, AND AIR IS BLOWN INTO THE DUCT UNTIL THE SPONGE COMES OUT FROM THE OTHER END. IF THE SPONGE DOES NOT COME OUT, THERE IS A PROBLEM IN THE DUCT LINE. CABLE BLOWING CANNOT BE PERFORMED UNTIL THE PROBLEM IS RESOLVED.

2) Machine Control

MONTAGE THE MACHINE TO PIPE AND LET PRESSURIZED AIR IN, AFTER YOU CHECKED THE SUITABILITY OF YOUR DUCT. WHEN PRESSURIZED AIR WENT OUR FROM THE END OF DUCT, YOU MUST SEE THESE VALUES:

AIR MOTOR PRESSURE: 6-7 BAR
PISTON PRESSURE: 2-4 BAR
DUCT PRESSURE: 10-12 BAR
(MACHINE AXIS MUST BE SET TO RUN)

3) Working Control

YOU MUST TRY TO STAY IN SAME LEVEL AS FAR AS POSSIBLE DUCT, MACHINE AND FIBRE OPTIC CABLE

CHECK OIL DROP VALUE THAT YOU NEED FOR AIR MOTORS ON AIR LUBRICANT (1 DROPS/MIN)

YOU MUST DO SHOCK LUBRICATION IN EVERY 150 METRES YOU INSTALLED.

YOU MUST LEAVE INSIDE OF AIR MOTORS OILY AFTER YOU USE THE MACHINE, TO DO THIS: LOOSEN THE OIL SET SCREW ON PREPERATION AIR LUBRICANT AND INCREASE THE SPEED OF OIL FLOW AND RUN MACHINE 3-4 MINS THIS POSITION.